

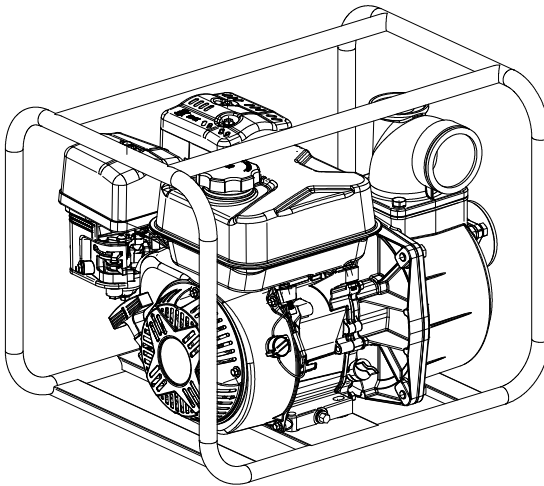

# OWNER'S MANUAL

**Water Pump**

**MODEL: SCWP50  
SPWP212**



**Original Instructions**

Thank you for purchasing a water pump.

This manual covers the operation and maintenance of water pump:  
SCWP50,SPWP212

The information and specifications included in this publication were in effect at the time of approval for printing.

No part of this publication may be reproduced without written permission.

This manual should be considered a permanent part of the pump and should remain with the pump if it is resold.

The illustrations in this manual are based in: SCWP50,SPWP212

The illustration may vary according to the type.

Keep this owner's manual handy, so you can refer to it at any time. This owner's manual is considered a permanent part of the water pump and should remain with the water pump if resold.

If a problem should arise, or if you have any questions about the pump, consult an authorised SGS engineer (contact SGS Engineering at 01332 576 850).

# CONTENTS

<b>IMPORTANT SAFETY INFORMATION .....</b>	<b>4</b>
<b>COMPONENTS &amp; CONTROL LOCATIONS.....</b>	<b>6</b>
<b>CHECK BEFORE OPERATION.....</b>	<b>7</b>
<b>OPERATION.....</b>	<b>11</b>
<b>STARTING THE ENGINE.....</b>	<b>14</b>
<b>STOPPING THE ENGINE.....</b>	<b>17</b>
<b>MAINTENANCE.....</b>	<b>18</b>
<b>MAINTENANCE SCHEDULE.....</b>	<b>20</b>
<b>TRANSPORTING / STORAGE.....</b>	<b>24</b>
<b>TROUBLESHOOTING.....</b>	<b>27</b>
<b>SPECIFICATION.....</b>	<b>29</b>

# IMPORTANT SAFETY INFORMATION

## Pump Safety

Your safety and the safety of others are very important. And using this water pump safely is an important responsibility.

To help you make informed decisions about safety, we have provided operating procedures and other information on labels and in this manual. This information alerts you to potential hazards that could hurt you or others.

Of course, it is not practical or possible to warn you about all the hazards associated with operating or maintaining a water pump. You must use your own good judgment.

You will find important safety information in a variety of forms, including:

Safety Labels — on the pump.

Safety Messages — preceded by a safety alert symbol  and one of three signal words, DANGER, WARNING, or CAUTION. These signal words mean:



**You WILL be KILLED or SERIOUSLY HURT if you don't follow instructions.**



**You CAN be KILLED or SERIOUSLY HURT if you don't follow instructions.**



**You CAN be HURT if you don't follow instructions.**

**NOTICE**

**Your pump or other property could be damaged if you don't follow instructions.**

Safety Headings — such as IMPORTANT SAFETY INFORMATION.

Safety Section — such as PUMP SAFETY.

Instructions — how to use this pump correctly and safely.

This entire book is filled with important safety information — please read it carefully.

## Engine Safety Information

Always make a pre-operation inspection before you start the engine. You may prevent an accident or equipment damage.

Most accidents can be prevented if you follow all instructions in this manual and on the pump. The most common hazards are discussed below, along with the best way to protect yourself and others.

## **Operator Responsibility**

It is the operator's responsibility to provide the necessary safeguards to protect people and property. Know how to stop the pump quickly in case of emergency. If you leave the pump for any reason, always turn the engine off. Understand the use of all controls and connections.

Be sure that anyone who operates the pump receives proper instruction. Do not let children operate the pump. Keep children and pets away from the area of operation.

## **Pump Operation**

Pump only water that is not intended for human consumption. Pumping flammable liquids, such as gasoline or fuel oils, can result in a fire or explosion, causing serious injury. Pumping sea water, beverages, acids, chemical solutions, or any other liquid that promotes corrosion can damage the pump.

## **Refuel With Care**

Gasoline is extremely flammable, and gasoline vapor can explode. Refuel outdoors, in a well-ventilated area, with the engine stopped and the pump on a level surface. Do not fill the fuel tank above the fuel strainer shoulder. Never smoke near gasoline, and keep other flames and sparks away. Always store gasoline in an approved container. Make sure that any spilled fuel has been wiped up before starting the engine. After refueling, make sure the tank cap closed properly and securely.

## **Hot Exhaust**

The muffler becomes very hot during operation and remains hot for a while after stopping the engine. Be careful not to touch the muffler while it is hot. Let the engine cool before transporting the pump or storing it indoors.

To prevent fire hazards, keep the pump at least 3 feet (1 meter) away from building walls and other equipment during operation. Do not place flammable objects close to the engine.

## **Carbon Monoxide Hazard**

Exhaust gas contains poisonous carbon monoxide. Avoid inhalation of exhaust gas. Never run the engine in a closed garage or confined area.

## COMPONENTS & CONTROL LOCATIONS

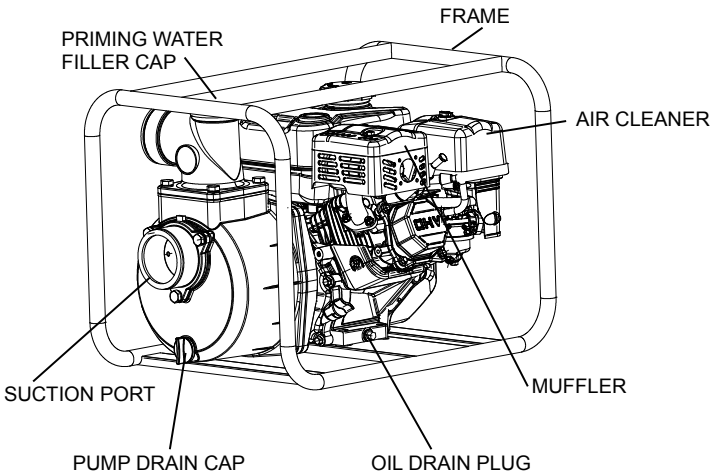
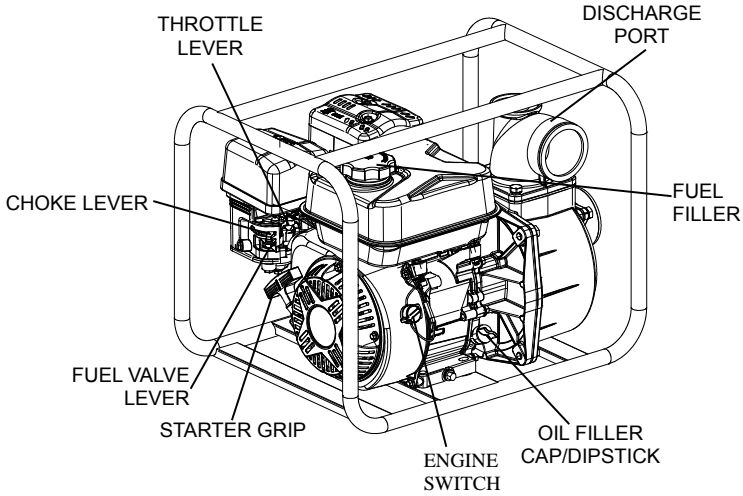

## CHECK BEFORE OPERATION

Be sure of what you are pumping. This pump is designed to pump only fresh water that is not intended for human consumption.

For your safety, and to maximize the service life of your equipment, it is very important to take a few moments before you operate the pump to check its condition. Be sure to take care of any problem you find, or have your servicing dealer correct it, before you operate the pump.



**Improperly maintaining this pump, or failing to correct a problem**

**before operation, could cause a malfunction in which you could be seriously injured.**

**Always perform a pre-operation inspection before each operation, and correct any problem.**

Exhaust gas contains poisonous carbon monoxide. Avoid inhalation of exhaust gas. Never run the engine in a closed garage or confined area.

To prevent fire hazards, keep the pump at least 3 feet (1 meter) away from building walls and other equipment during operation. Do not place flammable objects close to the engine.

Before beginning your pre-operation checks, be sure the pump is on a level surface and the ignition switch is in the OFF position.

### **Check the General Condition of the Pump**

Look around and underneath the pump for signs of oil or gasoline leaks.

Remove any excessive dirt or debris, especially around the engine muffler, and recoil starter.

Look for signs of damage.

Check that all nuts, bolts, screws, hose connectors and clamps are tightened.

### **Check the Suction and Discharge Hoses**

Check the general condition of the hoses. Be sure the hoses are in serviceable condition before connecting them to the pump. Remember that the suction hose must be reinforced construction to prevent hose collapse.

Check that the sealing washer in the suction hose connector is in good condition .

Check that the hose connectors and clamps are securely installed .

Check that the strainer is in good condition and is installed on the suction hose .

## Check Engine Oil Level

Check the engine oil level with the engine stopped and in a level position.

1. Remove the oil filler cap/dipstick and wipe it clean.
2. Insert and remove the dipstick without screwing it into the filler neck. Check the oil level shown on the dipstick.
3. If the oil level is low, fill to the edge of the oil filler hole with the recommended oil .
4. Screw in the oil filler cap/dipstick securely.

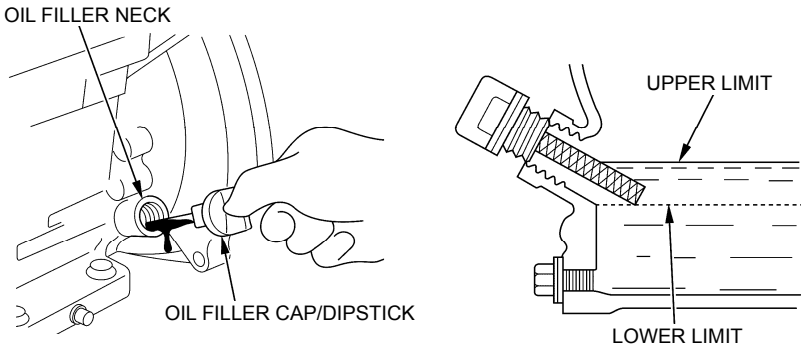

**WARNING** Running the engine with a low oil level can cause engine damage.

Engine oil capacities:

SCWP50,SPWP212: 0.6L

## Air Filter Inspection

A dirty air filter will restrict air flow to the carburetor, reducing engine and pump performance.

Remove the air cleaner cover and inspect the filter. Clean or replace dirty filter elements. Always replace damaged filter elements. If equipped with an oil-bath air cleaner, also check the oil level.

Reinstall the air filter and air cleaner cover. Be sure all the parts shown below are in place. Tighten the wing nut securely.

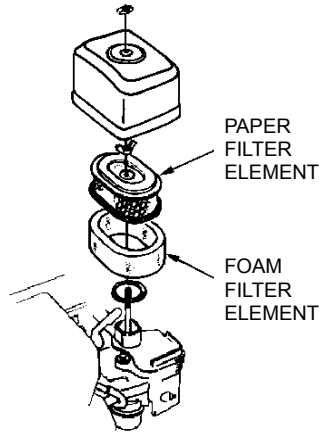

#### NOTICE

Operating the engine without an air filter, or with a damaged air filter, will allow dirt to enter the engine, causing rapid engine wear. This type of damage is not covered by the Distributor's Limited Warranty.

#### Check Fuel Level

With the engine stopped and on a level surface, remove the fuel tank cap and check the fuel level. Refill the tank if the fuel level is low. After refueling, tighten the fuel tank cap securely.



**WARNING** Gasoline is highly flammable and explosive. You can be burned or seriously injured when handling fuel.

- Stop the engine and keep heat, sparks, and flame away.
- Handle fuel only outdoors.
- Wipe up spills immediately.

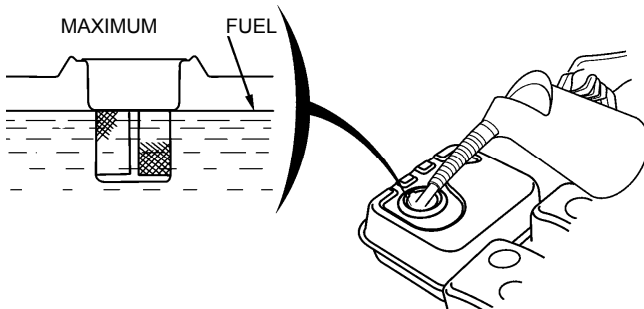

**NOTICE**

**Do not fill above the shoulder of the fuel strainer (maximum fuel level).**

**FUEL RECOMMENDATIONS**

**Use unleaded gasoline with a pump octane rating of 90 or higher.**

These engines are certified to operate on unleaded gasoline. Unleaded gasoline produces fewer engine and spark plug deposits and extends exhaust system life.

Never use stale or contaminated gasoline or an oil/gasoline mixture. Avoid getting dirt or water in the fuel tank.

Occasionally you may hear a light “spark knock” or “pinging” (metallic rapping noise) while operating under heavy loads. This is no cause for concern.

If spark knock or pinging occurs at a steady engine speed, under normal load, change brands of gasoline. If spark knock or pinging persists, see an authorized servicing dealer.

**NOTICE**

**Running the engine with persistent spark knock or pinging can cause engine damage.**

**Running the engine with persistent spark knock or pinging is misuse, and the Distributor’s Limited Warranty does not cover parts damaged by misuse.**

# OPERATION

## SAFE OPERATING PRECAUTIONS

To safely realize the full potential of this pump, you need a complete understanding of its operation and a certain amount of practice with its controls.

Before operating the pump for the first time, please review the IMPORTANT SAFETY INFORMATION on page 4 and the chapter titled CHECK BEFORE OPERATION.

For your safety, avoid starting or operating the engine in an enclosed area, such as a garage. Your engine's exhaust contains poisonous carbon monoxide gas which can collect rapidly in an enclosed area and cause illness or death.

Pump only fresh water that is not intended for human consumption. Pumping flammable liquids, such as gasoline or fuel oils, can result in a fire or explosion, causing serious injury. Pumping sea water, beverages, acids, chemical solutions, or any other liquid that promotes corrosion can damage the pump.

## PUMP PLACEMENT

For best pump performance, place the pump near the water level, and use hoses that are no longer than necessary. That will enable the pump to produce the greatest output with the least self-priming time.

As head (pumping height) increases, pump output decreases. The length, type, and size of the suction and discharge hoses can also significantly affect pump output.

Discharge head capability is always greater than suction head capability, so it is important for suction head to be the shorter part of total head.

Minimizing suction head (placing the pump near the water level) is also very important for reducing self-priming time. Self-priming time is the time that takes the pump to bring water the distance of the suction head during initial operation.

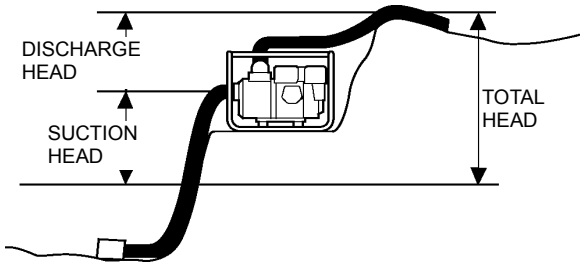

## SUCTION HOSE INSTALLATION

Use a commercially available hose and hose connector with the hose clamp provided with the pump. The suction hose must be reinforced with a non-collapsible wall or braided wire construction.

Do not use a hose smaller than the pump's suction port size. Minimum hose size:

SCWP50 = 2 in (50 mm);

SPWP212 = 3 in (80 mm);

The suction hose should be no longer than necessary. Pump performance is best when the pump is near the water level, and the hoses are short.

Use a hose clamp to securely fasten the hose connector to the suction hose in order to prevent air leakage and loss of suction. Verify that the hose connector sealing washer is in good condition.

Install the strainer (provided with the pump) on the other end of the suction hose, and secure it with a hose clamp. The strainer will help to prevent the pump from becoming clogged or damaged by debris.

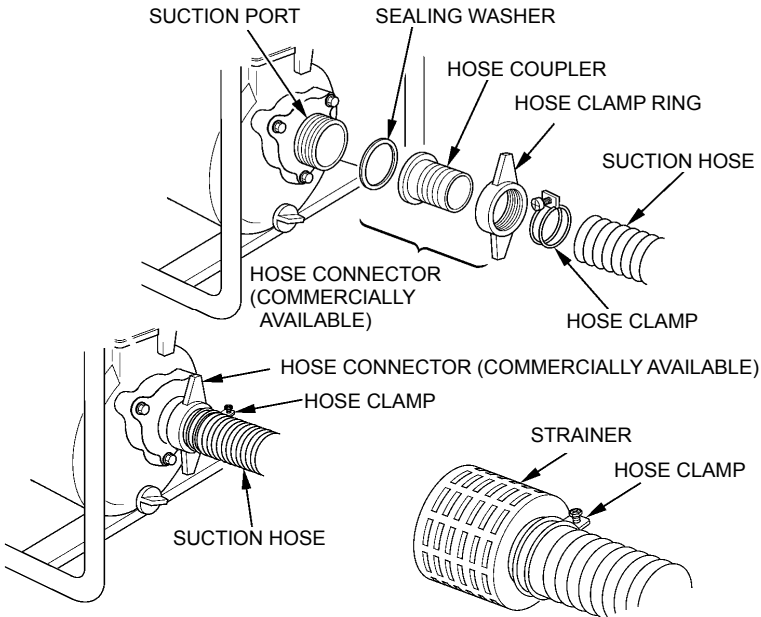

## DISCHARGE HOSE INSTALLATION

Use a commercially available hose and hose connector, and clamp provided with the pump.

It is best to use a short, large-diameter hose, because that will reduce fluid friction and improve pump output. A long or small-diameter hose will increase fluid friction and reduce pump output.

Tighten the hose clamp securely to prevent the discharge hose from disconnecting under pressure.

### PRIMING THE PUMP

Before starting the engine, remove the filler cap from the pump chamber, and completely fill the pump chamber with water. Reinstall the filler cap, and tighten it securely.

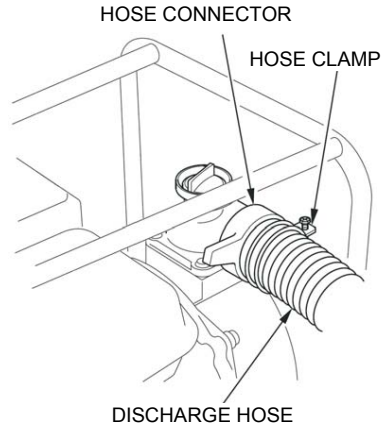

### NOTICE

Operating the pump dry will destroy the pump seal. If the pump has been operated dry, stop the engine immediately, and allow the pump to cool before priming.

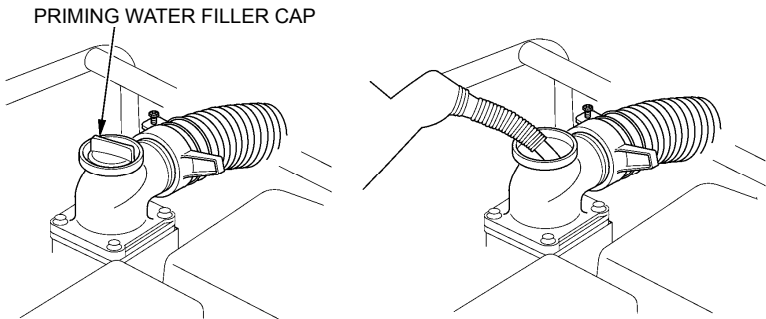

## STARTING THE ENGINE

Prime the pump .

1. Move the fuel valve lever to the ON position.

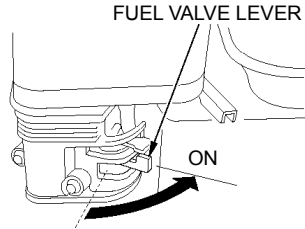

2. To start a cold engine, move the choke lever to the CLOSED position. To restart a warm engine, leave the choke lever in the OPEN position.

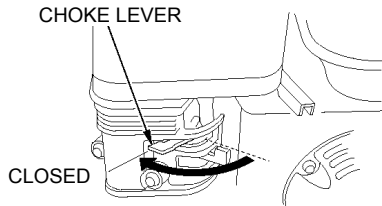

3. Move the throttle lever away from the SLOW position about 1/3 of the way toward the FAST position.

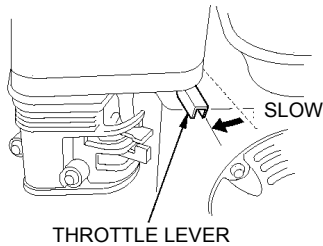

4. Turn the ignition switch to the ON position.

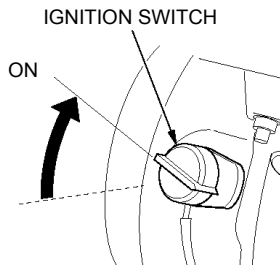

5. Pull the recoil starter grip lightly until resistance is felt, then pull it briskly. Do not allow the recoil starter grip to snap back against the engine. Return it gently to prevent damage to the starter.

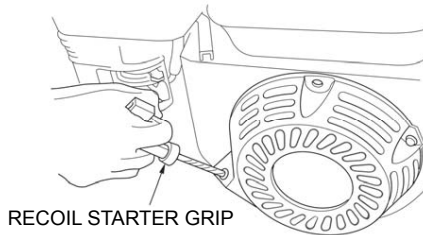

6. If the choke lever was moved to the CLOSED position to start the engine, gradually move it to the OPEN position as the engine warms up.

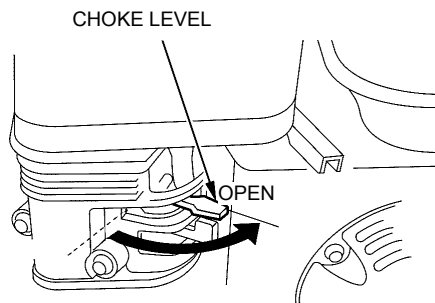

7. setting engine speed

After starting the engine, move the throttle lever to the FAST position for self-priming, and check pump output.

Pump output is controlled by adjusting engine speed. Moving the throttle lever in the FAST direction will increase pump output, and moving the throttle lever in the SLOW direction will decrease pump output.

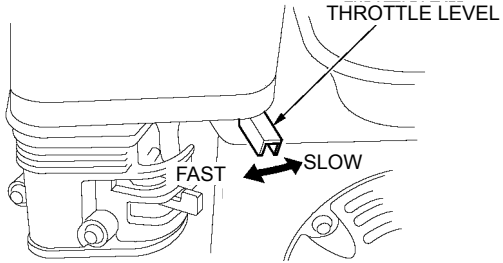

## STOPPING THE ENGINE

To stop the engine in an emergency, simply turn the ignition switch to the OFF position. Under normal conditions, use the following procedure.

1. Move the throttle lever to the SLOW position.

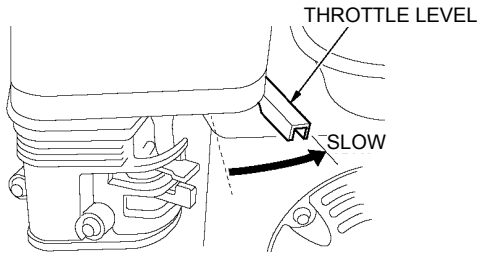

2. Turn the ignition switch to the OFF position.

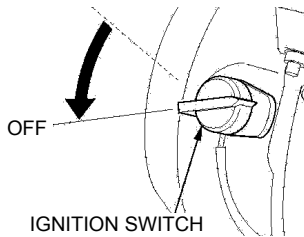

3. Turn the fuel valve lever to the OFF position.

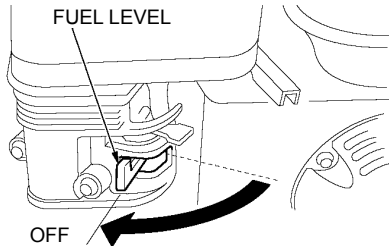

After use, remove the pump drain plug , and drain the pump chamber. Remove the filler cap, and flush the pump chamber with clean, fresh water. Allow the water to drain from the pump chamber, then reinstall the filler cap and drain plug.

# MAINTENANCE

## THE IMPORTANCE OF MAINTENANCE

Good maintenance is essential for safe, economical, and trouble-free operation. It will also help reduce air pollution.



**WARNING** Improperly maintaining this pump, or failing to correct a problem before operation, can cause a malfunction in which you can be seriously hurt or killed.

**Always follow the inspection and maintenance recommendations and schedules in this owner's manual.**

To help you properly care for your pump, the following pages include a maintenance schedule, routine inspection procedures, and simple maintenance procedures using basic hand tools. Other service tasks that are more difficult, or require special tools, are best handled by professionals and are normally performed by a technician or other qualified mechanic.

The maintenance schedule applies to normal operating conditions. If you operate your pump under severe conditions, such as sustained high-load or high-temperature operation, or use in unusually wet or dusty conditions, consult your servicing dealer for recommendations applicable to your individual needs and use.

Remember that your servicing dealer knows your pump best and is fully equipped to maintain and repair it.

To ensure the best quality and reliability, use only new, genuine parts or their equivalents for repair and replacement.

**Maintenance, replacement, or repair of emission control devices and systems may be performed by any engine repair establishment or individual, using parts that are "certified" to EPA standards.**

## MAINTENANCE SAFETY

Some of the most important safety precautions follow. However, we cannot warn you of every conceivable hazard that can arise in performing maintenance. Only you can decide whether or not you should perform a given task.



**WARNING** Failing to properly follow maintenance instructions and precautions can cause you to be seriously hurt or killed.

**Always follow the procedures and precautions in the owner's manual.**

### Safety Precautions

Make sure the engine is off before you begin any maintenance or repairs. This will eliminate several potential hazards:

- Carbon monoxide poisoning from engine exhaust.

Be sure there is adequate ventilation whenever you operate the engine.

— **Burns from hot parts.**

Let the engine and exhaust system cool before touching.

— **Injury from moving parts.**

Do not run the engine unless instructed to do so.

Read the instructions before you begin, and make sure you have the tools and skills required.

To reduce the possibility of fire or explosion, be careful when working around gasoline. Use only a nonflammable solvent, not gasoline, to clean parts. Keep cigarettes, sparks, and flames away from all fuel-related parts.

## MAINTENANCE SCHEDULE

Performed at every indicated month or operating hour interval, whichever comes first.		Each use	First month or 20 Hrs.	Every 3 months or 50 Hrs.	Every 6 months or 100 Hrs.	Every year or 300 Hrs.
ITEM						
• Engine oil	Check level	○				
	Change		○		○	
• Air cleaner	Check	○				
	Clean			○(1)		
• Idle speed	Check-Adjust					○(2)
• Spark plug	Check-Clean				○	
• Spark arrester	Clean				○	
• Combustion chamber	Clean					○(2)
• Valve clearance	Check-Adjust					○(2)
• Fuel tank and strainer	Clean					○(2)
• Fuel tube	Check	Every 2 years(Replace if necessary) (2)				
Impeller	Check					○(2)
Impeller clearance	Check					○(2)
Pump inlet valve	Check					○(2)

• Emission-related items.

(1) Service more frequently when used in dusty areas.

(2) These items should be serviced by your servicing dealer, unless you have the proper tools and are mechanically proficient. Refer to shop manual for service procedures.

### REFUELING

Fuel tank capacities:

SCWP50,SPWP212: 0.6L

With the engine stopped and on a level surface, remove the fuel tank cap and check the fuel level. Refill the tank if the fuel level is low.

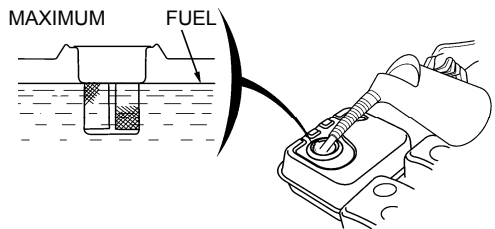

Refuel in a well-ventilated area before starting the engine. If the engine has been running, allow it to cool. Refuel carefully to avoid spilling fuel. Do not fill the fuel tank above the fuel strainer shoulder. After refueling, tighten the fuel tank cap securely.

Never refuel the engine inside a building where gasoline fumes may reach flames or sparks. Keep gasoline away from appliance pilot lights, barbecues, electric appliances, power tools, etc.

Spilled fuel is not only a fire hazard, it causes environmental damage. Wipe up spills immediately.

**NOTICE** Do not fill above the shoulder of the fuel strainer (maximum fuel level).

Refuel in a well-ventilated area before starting the engine. If the engine has been running, allow it to cool. Refuel carefully to avoid spilling fuel. Do not fill the fuel tank above the fuel strainer shoulder. After refueling, tighten the fuel tank cap securely.

Never refuel the engine inside a building where gasoline fumes may reach flames or sparks. Keep gasoline away from appliance pilot lights, barbecues, electric appliances, power tools, etc.

Spilled fuel is not only a fire hazard, it also causes environmental damage. Wipe up spills immediately.

**NOTICE** Fuel can damage paint and plastic. Be careful not to spill fuel when filling your fuel tank. Damage caused by spilled fuel is not covered under warranty.

### ENGINE OIL CHANGE

Drain the used oil while the engine is warm. Warm oil drains quickly and completely.

1. Place a suitable container below the engine to catch the used oil, and then remove the oil filler cap/dipstick, drain plug and sealing washer.
2. Allow the used oil to drain completely, and then reinstall the drain plug, and tighten it securely.

Please dispose of used motor oil in a manner that is compatible with the environment. We suggest you take used oil in a sealed container to your local recycling center or service station for reclamation. Do not throw it in the trash; pour it on the ground, or down a drain.

3. With the engine in a level position, fill to the outer edge of the oil filler hole with the recommended oil.

Engine oil capacities:

SCWP50,SPWP212: 0.6L

**NOTICE** Running the engine with a low oil level can cause engine damage.

4. Screw in the oil filler cap/dipstick securely.

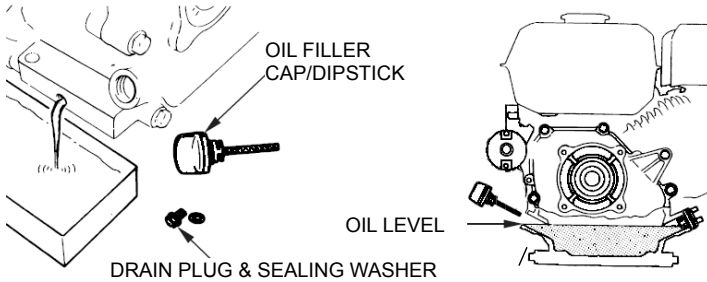

**ENGINE OIL RECOMMENDATIONS**

Oil is a major factor affecting performance and service life. Use 4-stroke automotive detergent oil.

SAE 10W-30 is recommended for general use. Other viscosities shown in the chart may be used when the average temperature in your area is within the recommended range.

SAE Viscosity Grades

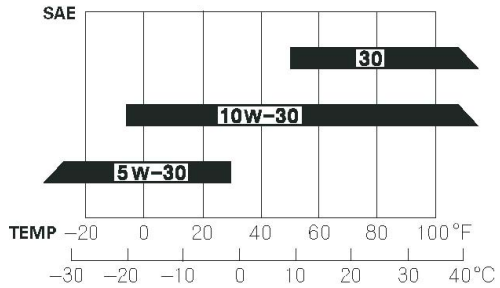

**AMBIENT TEMPERATURE**

The SAE oil viscosity and service classification are in the API label on the oil container. We recommend that you use API SERVICE category SJ oil.

The recommended operating range of this pump is 23 °F to 104 °F ( -5 °C to 40 °C).

**AIR FILTER CLEANING**

A dirty air filter will restrict air flow to the carburetor, reducing engine performance. If you operate the pump in very dusty areas, clean the air filter more frequently than specified in the MAINTENANCE SCHEDULE .

1. Clean the air filter in warm soapy water, rinse, and dry it thoroughly. Or clean in nonflammable solvent and dry it thoroughly.

2. Dip the air filter in clean engine oil, and then squeeze out all excess oil. The engine will smoke when started if too much oil is left in the foam.
3. Wipe dirt from the air cleaner base and cover, using a moist rag. Be careful to prevent dirt from entering the air duct that leads to the carburetor.

## SPARK PLUG SERVICE

Recommended spark plug: F7TC, F7RTC or other equivalents.

**NOTICE** Incorrect spark plugs can cause engine damage.

1. Disconnect the spark plug cap, and remove any dirt from around the spark plug area.
2. Remove the spark plug with a spark plug wrench.
3. Inspect the spark plug. Replace it if the electrodes are worn, or if the insulator is cracked or chipped.

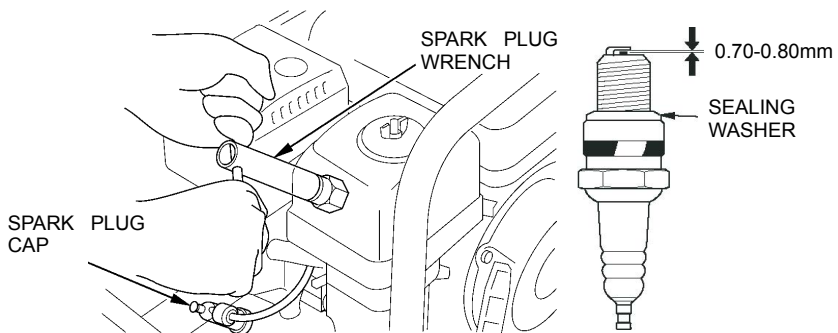

4. Measure the spark plug electrode gap with a suitable gauge. Correct the gap if necessary, by carefully bending the side electrode. The gap should be: 0.028—0.031 in (0.70—0.80 mm).

5. Install the spark plug carefully, by hand, to avoid cross-threading.

6. After the spark plug seats, tighten with a spark plug wrench to compress the sealing washer.

If reinstalling the used spark plug, tighten 1/8—1/4 turn after the spark plug seats.

If installing a new spark plug, tighten 1/2 turn after the spark plug seats.

## TRANSPORTING / STORAGE

Proper storage preparation is essential for keeping your pump troublefree and looking good. The following steps will help to keep rust and corrosion from impairing your pump's function and appearance, and will make the engine easier to start when you use the pump again.

### Cleaning

1. Wash the engine and pump.

Wash the engine by hand, and be careful to prevent water from entering the air cleaner or muffler opening. Keep water away from controls and all other places that are difficult to dry, as water promotes rust.

#### NOTICE

• **Using a garden hose or pressure washing equipment can force water into the air cleaner or muffler opening. Water in the air cleaner will soak the air filter, and water that passes through the air filter or muffler can enter the cylinder, causing damage.**

• **Water contacting a hot engine can cause damage. If the engine has been running, allow it to cool for at least half an hour before washing.**

2. Wipe dry all accessible surfaces.
3. Fill the pump chamber with clean, fresh water, start the engine outdoors, and let it run until it reaches normal operating temperature to evaporate any external water.

#### NOTICE

**Dry operation will damage the pump seal. Be sure the pump chamber is filled with water before starting the engine.**

4. Stop the engine, and allow it to cool.
5. Remove the pump drain plug, and flush the pump with clean, fresh water. Allow the water to drain from the pump chamber, and then reinstall the drain plug.
6. After the pump is clean and dry, touch up any damaged paint, and coat areas that may rust with a light film of oil. Lubricate controls with a silicone spray lubricant.

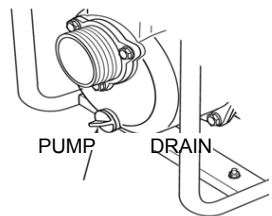

### Fuel

Gasoline will oxidize and deteriorate in storage. Old gasoline will cause hard starting, and it leaves gum deposits that clog the fuel system. If the gasoline in your engine deteriorates during storage, you may need to have the carburetor

and other fuel system components serviced or replaced.

The length of time that gasoline can be left in your fuel tank and carburetor without causing functional problems will vary with such factors as gasoline blend, your storage temperatures, and whether the fuel tank is partially or completely filled. The air in a partially filled fuel tank promotes fuel deterioration. Very warm storage/temperatures accelerate fuel deterioration. Fuel deterioration problems may occur within a few months, or even less if the gasoline was not fresh when you filled the fuel tank.

The Distributor's Limited Warranty does not cover fuel system damage or engine performance problems resulting from neglected storage preparation.

You can extend fuel storage life by adding a fuel stabilizer that is formulated for that purpose, or you can avoid fuel deterioration problems by draining the fuel tank and carburetor.

### Adding a Fuel Stabilizer to Extend Fuel Storage Life

When adding a fuel stabilizer, fill the fuel tank with fresh gasoline. If only partially filled, air in the tank will promote fuel deterioration during storage. If you keep a container of gasoline for refueling, be sure that it contains only fresh gasoline.

1. Add fuel stabilizer following the manufacturer's instructions.
2. After adding a fuel stabilizer, run the engine outdoors for 10 minutes to be sure that treated gasoline has replaced the untreated gasoline in the carburetor.

**NOTICE** Dry operation will damage the pump seal. Be sure the pump chamber is filled with water before starting the engine.

3. Stop the engine, and move the fuel valve lever to the OFF position.

### Draining the Fuel Tank and Carburetor

1. Place an approved gasoline container below the carburetor, and use a funnel to avoid spilling fuel.
2. Remove the carburetor drain bolt and sediment cup, and then move the fuel valve lever to the ON position.

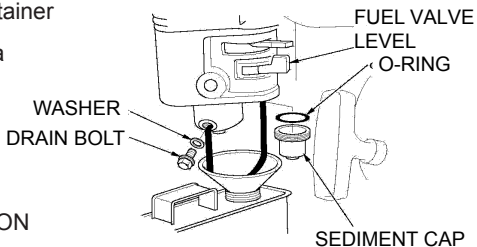

3. After all the fuel has drained into the container, reinstall the drain bolt and sediment cup. Tighten them securely.

## **STORAGE PROCEDURE**

1. Change the engine oil .
2. Remove the spark plug .
3. Pour a tablespoon (5— 10 cc) of clean engine oil into the cylinder.
4. Pull the starter grip several times to distribute the oil in the cylinder.
5. Reinstall the spark plug and attach the spark plug cap.
6. Pull the recoil starter grip slowly until resistance is felt. This will close the valves so moisture cannot enter the engine cylinder. Return the recoil starter grip gently.

## **STORAGE PRECAUTIONS**

If your pump will be stored with gasoline in the fuel tank and carburetor, it is important to reduce the hazard of gasoline vapor ignition. Select a well-ventilated storage area away from any appliance that operates with a flame, such as a furnace, water heater, or clothes dryer. Also avoid any area with a spark-producing electric motor, or where power tools are operated.

If possible, avoid storage areas with high humidity, because that promotes rust and corrosion.

Unless all fuel has been drained from the fuel tank, leave the fuel valve lever in the OFF position to reduce the possibility of fuel leakage.

Place the pump on a level surface. Tilting can cause fuel or oil leakage.

With the engine and exhaust system cool, cover the pump to keep out dust. A hot engine and exhaust system can ignite or melt some materials. Do not use sheet plastic as a dust cover. A nonporous cover will trap moisture around the pump, promoting rust and corrosion.

## **REMOVAL FROM STORAGE**

Check your pump as described in the CHECK BEFORE OPERATION chapter of this manual.

If the fuel was drained during storage preparation, fill the tank with fresh gasoline. If you keep a container of gasoline for refueling, be sure that it contains only fresh gasoline. Gasoline oxidizes and deteriorates over time, causing hard starting.

If the cylinder was coated with oil during storage preparation, the engine may smoke briefly at startup. This is normal.

## **TRANSPORTING**

If the pump has been running, allow the engine to cool for at least 15 minutes before loading the pump on the transport vehicle. A hot engine and exhaust system can burn you and can ignite some materials.

Keep the pump level when transporting to reduce the possibility of fuel leakage. Move the fuel valve lever to the OFF position.

## TROUBLESHOOTING

### ENGINE

Engine Will Not Start	Possible Cause	Correction
1. Check control positions.	Fuel valve OFF.	Move fuel valve lever to ON position.
	Choke open.	Move choke lever to CLOSED position unless engine is warm.
	Ignition switch OFF.	Turn ignition switch to ON.
2. Check fuel.	Out of fuel.	Refuel
	Bad fuel; pump stored without treating or draining gasoline, or refuel with bad gasoline.	Drain fuel tank and carburetor. Refuel with fresh gasoline
3. Remove and inspect spark plug.	Spark plug faulty, fouled, or improperly gapped.	Gap or replace spark plug
	Spark plug wet with fuel (flooded engine).	Dry and reinstall spark plug. Start engine with throttle lever in FAST position.
4. Take engine to an authorized servicing dealer, or refer to shop manual.	Fuel filter clogged, carburetor malfunction, ignition malfunction, valves stuck, etc.	Replace or repair faulty components as necessary.

Engine Lacks Power	Possible Cause	Correction
1. Check air filter.	Air filter clogged.	Clean or replace filter.
2. Check fuel.	Bad fuel; pump stored without treating or draining gasoline, or refuel with bad gasoline.	Drain fuel tank and carburetor . Refuel with fresh gasoline
3. Take engine to an authorized servicing dealer, or Refer to shop manual.	Fuel filter clogged, carburetor malfunction, ignition malfunction, valves stuck, etc.	Replace or repair faulty components as necessary.

## PUMP

No Pump Output	Possible Cause	Correction
1. Check pump chamber.	Pump not primed.	Prime the pump
2. Check suction hose.	Hose collapsed, cut or punctured.	Replace suction hose
	Strainer not completely underwater.	Sink the strainer and the end of a suction hose completely underwater.
	Air leak at connector.	Replace sealing washer if missing or damaged. Tighten hose connector and clamp
	Strainer clogged.	Clean debris from strainer.
3. Measure suction and discharge head.	Excessive head.	Relocate pump and/or hoses to reduce head
4. Check engine.	Engine lacks power.	See page 26.

Low Pump Output	Possible Cause	Correction
1. Check suction hose.	Hose collapsed, damaged, too long, or diameter too small.	Replace suction hose
	Air leak at connector.	Replace sealing washer if missing or damaged. Tighten hose connector and clamp
	Strainer clogged.	Clean debris from strainer.
2. Check discharge hose.	Hose damaged, too long, or diameter too small.	Replace discharge hose
3. Measure suction and discharge head.	Marginal head.	Relocate pump and/or hoses to reduce head
4. Check engine.	Engine lacks power.	

## SPECIFICATION

Iten	Type	SCWP50	SPWP212
Pump	Suction port diameter	50mm(2inch)	80mm(3 inch)
	Discharge port diameter	50mm(2inch)	80mm(3 inch)
	Suck Grade(m)	7.5	7.5
	Lift(m)	32	28
Engine	Volume of Flow(m <sup>3</sup> /h )	28	58
	Model	DH212	DH212
	Type	4-Stroke	4-Stroke
	Displacement(cc)	212cc	212cc
	Fuel tank capacity(L)	3.6	3.6
	Oil capacity(L)	0.6	0.6



# EC DECLARATION OF CONFORMITY



**For the following machinery**

- Product name: Water Pump
- Model No.: SCWP50&SPWP212
- Commercial name: Water Pump
- Function:
- Type: Gasoline
- Serial No.:

**is herewith confirmed to fulfill all the relevant provisions of**

- Machinery Directive (2006/42/EC)

**and the following harmonized standard have been complied with**

- EN 809:1998+A1;
- EN 809:1998+A1/AC

**is herewith confirmed to fulfill all the relevant provisions of**

- Electromagnetic Compatibility Directive (2014/30/EU)

**and the following harmonized standard have been complied with**

- EN 61000-6-1:2007;
- EN 55012:2007+A1

**is herewith confirmed to fulfill all the relevant provisions of**

- Noise Emission Directive by equipment for use outdoors (2000/14/EC + 2005/88/EC)

**and conformity Assessment Procedure: 2000/14/EC, amended by 2005/88/EC- Annex VI**

- Measured Sound Power Level – LwA 105 dB(A)
- Guarantee Sound Power Level – LwA 105 dB(A)

**Responsible for marking this declaration is the**

Manufacturer's Name : Chongqing Manufacturer's Name Dajiang Power Equipment Co.,Ltd.  
Manufacturer's Address : Qinggang Industrial Zone, Chongqing 402761, P.R. China

**Person responsible for making this declaration**

Name, Surname Neil Sansom  
Position/Title CEO  
Place Derby, UK  
Date 20th November 2024

**(CEO Signature)**